

for solid-fuel heating systems

ebm-papst Mulfingen GmbH & Co. KG

Bachmühle 2 · D-74673 Mulfingen

Phone +49 7938 81-0

Fax +49 7938 81-110

info1@de.ebmpapst.com

www.ebmpapst.com

Limited partnership · Headquarters Mulfingen

Amtsgericht (court of registration) Stuttgart · HRA 590344

General partner Elektrobau Mulfingen GmbH · Headquarters Mulfingen

Amtsgericht (court of registration) Stuttgart · HRB 590142

Nominal data

Type	R2E150-AN89-11	
Motor	M2E068-BF	
Phase		1~
Nominal voltage	VAC	115
Frequency	Hz	60
Method of obtaining data		fa
Valid for approval/standard		UL 2111
Power consumption	W	40
Capacitor	µF	3
Capacitor voltage	VDB	220
Capacitor standard		UL
Min. back pressure	Pa	0
Min. back pressure	inH ₂ O	0
Min. ambient temperature	°C	-25
Max. ambient temperature	°C	80

ml = Max. load · me = Max. efficiency · fa = Free air · cs = Customer specification · ce = Customer equipment
Subject to change



Technical description

Weight	1.7 kg
Fan size	150 mm
Rotor surface	Unpainted
Impeller material	Sheet steel, stainless
Number of blades	6
Direction of rotation	Counterclockwise, viewed toward rotor
Degree of protection	IP44; installation- and position-dependent
Insulation class	"B"
Moisture (F) / Environmental (H) protection class	H0 - dry environment
Max. permitted ambient temp. for motor (transport/storage)	+ 80 °C
Min. permitted ambient temp. for motor (transport/storage)	- 40 °C
Installation position	Any
Mode	S1
Motor bearing	Ball bearing
Touch current according to IEC 60990 (measuring circuit Fig. 4, TN system)	< 0.75 mA
Motor protection	Thermal overload protector (TOP) internally connected
With cable	Variable
Protection class	I (with customer connection of protective earth)
Motor capacitor according to EN 60252-1 in safety protection class	S2
Conformity with standards	EN 60335-1; CE
Approval	CSA C22.2 No. 77; UL 2111

Product drawing

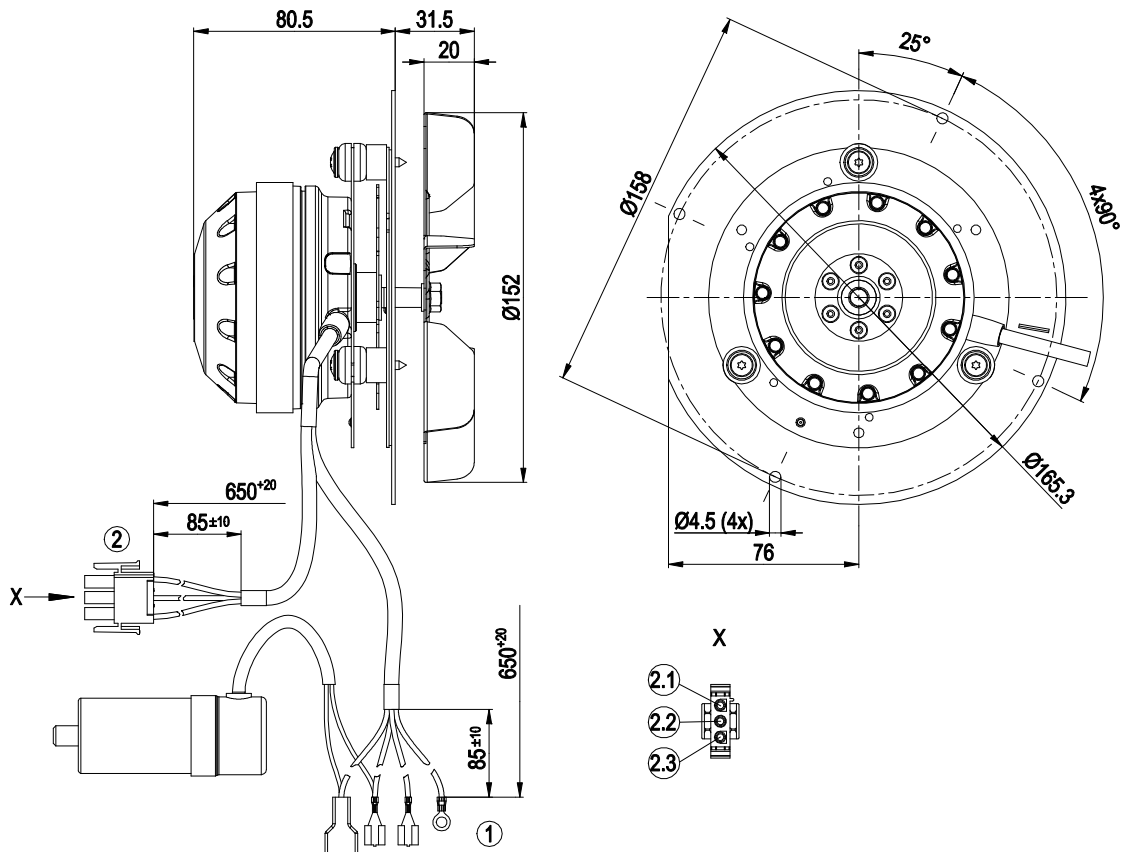

1	Cable AWG20; 1x ring terminal, 1x flat push-on receptacle 160389-3 and 2x flat push-on receptacle 3-160256-1
2	AMP connector housing 350766-4 with 3x plug pin 926885-1
2.1	+ (red)
2.2	0 V (black)
2.3	out (white)

Connection diagram

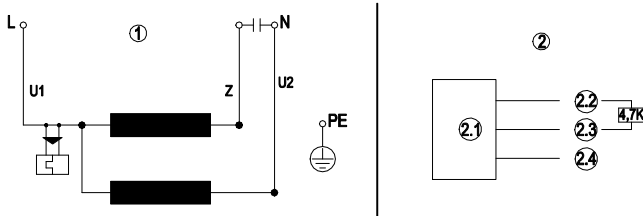

1	Fan connection diagram
U1	blue
Z	brown
U2	black
PE	green/yellow
2	Hall IC circuit
2.1	Hall IC
2.2	red (+5 V)
2.3	white (out)
2.4	black (0 V)

Curves: Air performance 60 Hz

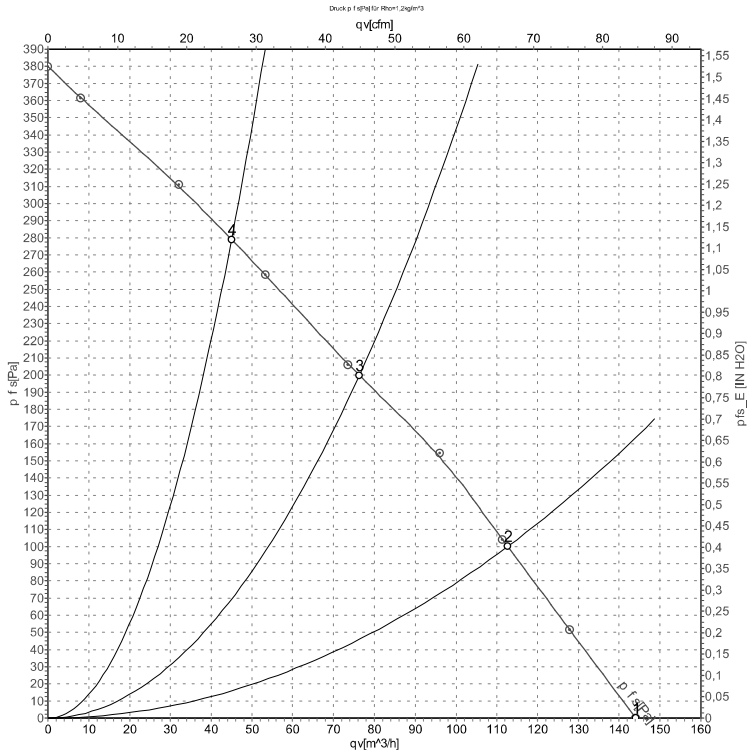

Measurement: LU-13862-1

Air performance measured according to ISO 5801 installation category A. For detailed information on the measurement setup, contact ebm-papst. Intake sound level: Sound power level according to ISO 13347 / sound pressure level measured at 1 m distance from fan axis. The values given are valid under the specified measuring conditions and may vary due to conditions of installation. For deviations from the standard configuration, the parameters have to be checked on the installed unit.

Measured values

	U	f	n	P _e	I	q _v	P _{ts}	q _v	P _{ts}
	V	Hz	min ⁻¹	W	A	m ³ /h	Pa	cfm	inH ₂ O
1	115	60	2550	33	0.30	145	0	85	0.00
2	115	60	2635	32	0.28	115	100	65	0.40
3	115	60	2755	31	0.27	75	200	45	0.80
4	115	60	2865	30	0.26	45	280	25	1.12

U = Power supply · f = Frequency · n = Speed (rpm) · P_e = Power consumption · I = Current draw · q_v = Air flow · p_{ts} = Pressure increase

